

HPH spol.s r.o.
Čáslavská 234
CZ284 01 Kutná Hora
Czech Republic
Tel/Fax 00420-327 513441
e-mail : info@hph.cz

Service bulletin

No.: G304S – 15 a)

Type :

TC(s) no.: EASA.A.030
Model(s): Glasflügel 304MS

Serial no(s): Up to and including 208-MS

Subject :

Modification of starter power cables

Urgency:

Action 1 and Action 2

Within the next 20 flight hours or 90 days, whichever comes first after effective day of this Service bulletin.

Effective day: 5.3.2026

Reason:

Action 1 - Limitation of unprotected length of starter power cables
Action 2 - Adjustment of connector terminal connection to ensure proper contact

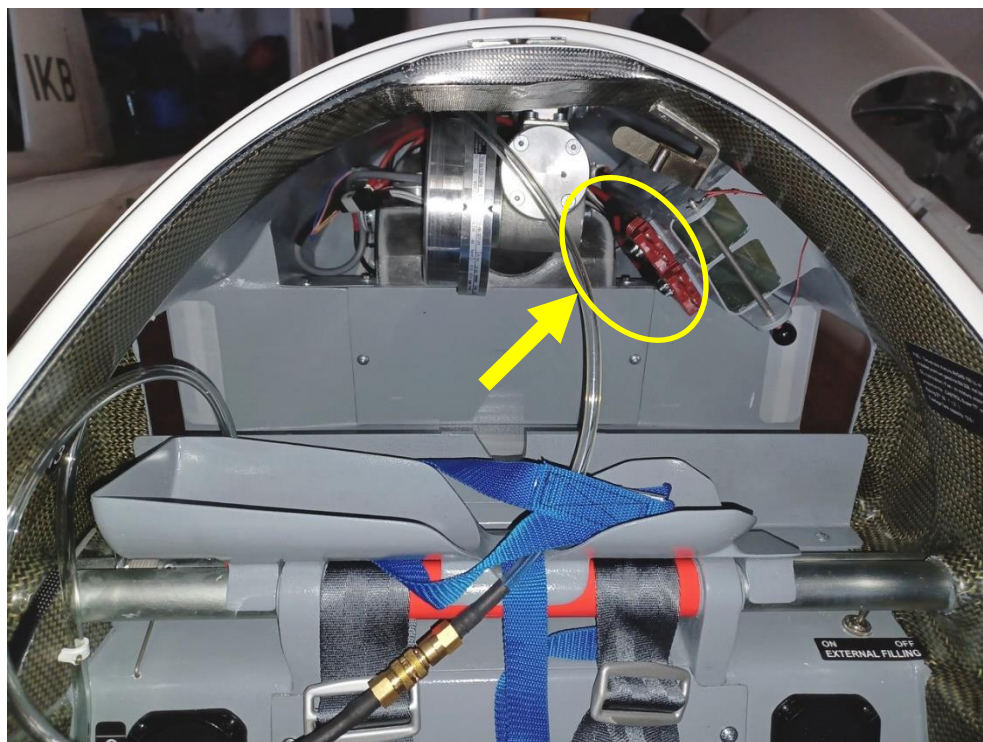

Fig. 1 – Starter battery connectors in the luggage compartment area behind the pilot's headrest

Page 1/5

HPH, spol.s.r.o.
Čáslavská 234
CZ284 01 Kutná Hora
Czech republic

The technical content of this document is approved under the authority of EASA (ref. approval no. 10089390; 5.3.2026) and have been produced in accordance with alternative procedure to DOA no. EASA.AP198.

Datum 11.12.2025
EASA DOA AP no. 198
Issued by
Jaroslav Potměšil

Action 1:

Replacement of starter battery cables

Check if fuse boxes are present as shown in Fig. 3. If not, replace the cables for both starter batteries with new cables with pre-installed 80A fuses as follows.

The battery holders are located on the left side of the luggage compartments behind the pilot's headrest (see Fig. 1).

Procedure:

- 1) Remove both starter batteries out of the holders. Store them securely.
- 2) Disconnect avionic power sources.
- 3) Check that both the main switch and engine main switch are off.
- 4) Disconnect the battery cables from the starter relay.
The relay is located on the right side of the rear luggage compartment wall (see Fig. 2).

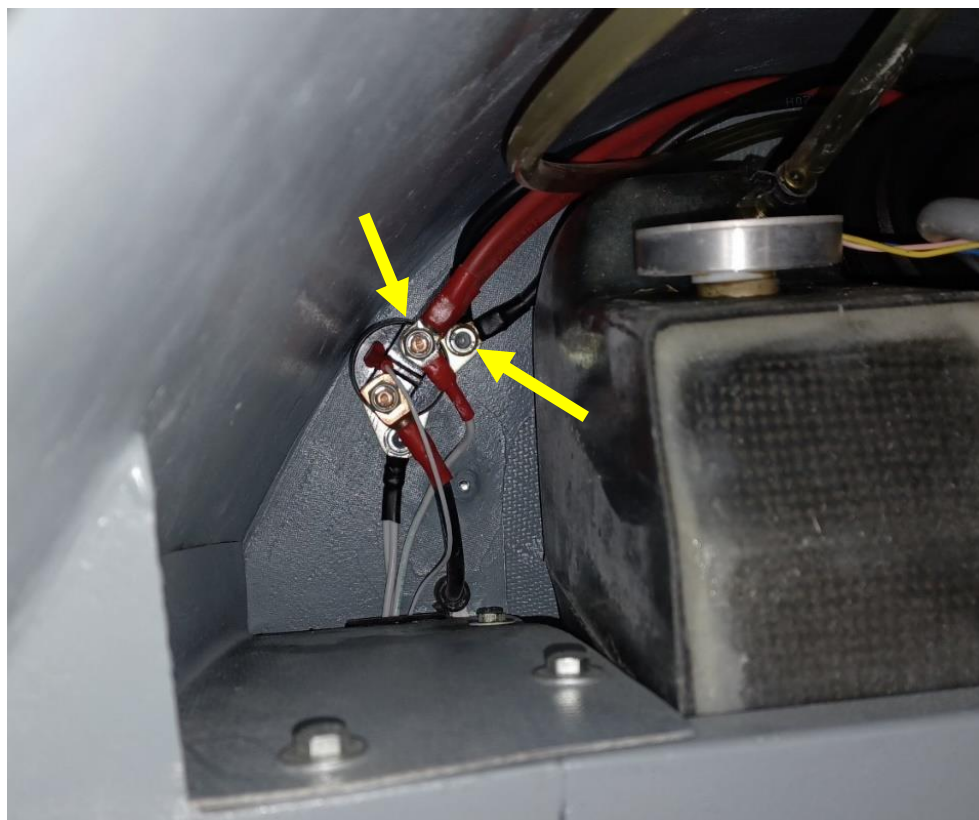

Fig. 2 – Starter relay, battery cable ends to be disconnected marked by arrows

Action 1 (cont.):

- 5) Remove the battery connectors on the other end of the cables from the battery holder, carefully pull the cables out
- 6) Replicate the routing of the original cables with the new cables, then attach on the relay end (see Fig. 2 for end result)
- 7) Attach the battery connectors back in their original positions. The fuse covers shall have their bases aligned to the battery holder, but are not otherwise secured – see Fig. 3.
- 8) Check the system function.



Fig. 3 – Replacement cable after installation.

Action 2:

Check if inserts (see Fig. 4 pos. 9) are present. If not, proceed with modification of the connector terminal through the inserts to limit the cable movement and assuring proper terminal position.

Procedure:

- 1) Open the 304S-82-90 insert and position its grooved end for the tie wrap away from the connector.
- 2) Close the insert, then secure it lightly with a tie wrap.
- 3) Slide the connector insert into the connector opening along the cable until the tie wrap touches the connector end. Fasten the tie wrap firmly and adjust its free end.
- 4) Repeat this procedure for all individual cables entering both starter battery connectors.

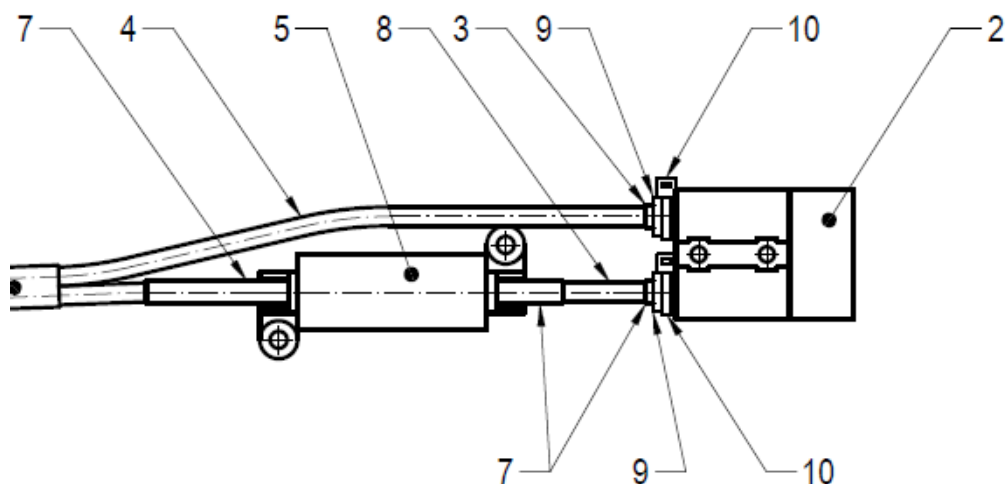

Fig. 4 – Assembly of starter battery connector:

Connector (2) with connector inserts 304S-82-90 (9);

secured by cable ties (10); shrink tube – black (3) and red (7)

| | | |
|---|--|---|
| HPH spol.s r.o. Čáslavská 234 CZ284 01 Kutná Hora Czech Republic Tel/Fax 00420-327 513441 e-mail : <i>info@hph.cz</i> | Service bulletin | No.: G304S – 15 a) |
| <p>Material:</p> <ul style="list-style-type: none"> - Action 1: <ul style="list-style-type: none"> o Cable bundle (304S-82-89-01), 2pcs o Drawing 304S-82-89-00 - Action 2: <ul style="list-style-type: none"> o 304S-82-90 connector inserts, 4pcs o Cable ties, 4pcs <p>Weight : Negligible</p> <p>C.G. Position : Negligible</p> <p>Remarks: All maintenance work must be carried out and certified by qualified and authorized personnel.</p> <p>Action costs are covered by the owner.</p> | | |
| Page 5/5 | | |
| HPH, spol.s.r.o. Čáslavská 234 CZ284 01 Kutná Hora Czech republic | The technical content of this document is approved under the authority of EASA (ref. approval no. 10089390; 5.3.2026) and have been produced in accordance with alternative procedure to DOA no. EASA.AP198. | Datum 11.12.2025 EASA DOA AP no. 198 Issued by Jaroslav Potměšil |